

## Automatic Flow Controller

### FLOSTAT TYPE FV

Platon Type FV Flostats automatically regulate the flow of liquids, gases or steam by using available line pressure. Once adjusted to the required value, flow is maintained accurately at this rate independent of supply pressure fluctuations or varying back pressure downstream of the meter. No electrical power or external flow measurement input is required – the Flostat control system uses the available line pressure to control the balanced control valve, maintaining the flow rate at the operator preset value.

Accurate flow control is vital to a wide variety of processes, for example blending and dosing applications. By keeping the required fluid delivery rate constant, a Flostat can ensure consistent product quality irrespective of process liquid head changes throughout a batch.

Flostat Type FV Flow controllers are used in flow control systems such as aircraft fuel delivery systems, to prevent the hazard of excessive flows and protect metering systems from over-speeding. On natural gas or fuel oil delivery systems to multiple burners, Flostat units can maintain optimum flow rate to each burner independently.

Available in sizes from 15mm to 100mm, all Type FV units can be fitted with a flow scale plate calibrated for process conditions.



### FEATURES

- Fully automatic flow control
- No power required
- 1/2" – 4" line sizes
- 10:1 control range
- Fast response
- Suitable for hazardous liquids or gases

The Flostat combines, in one body, a flow measuring orifice (A) and a balanced control valve (B). With no flow through the Flostat, the compressed spring opens the double seated valve. When flow commences, a pressure drop  $P_1-P_2$  is generated across the orifice (A). This pressure drop also acts on the diaphragm C, closing the valve against the spring force. The downstream pressure  $P_3$  has no net effect on the control valve position, because the valve is double seated. At equilibrium, the spring force, a constant, is equal to the orifice pressure drop, making the fluid flow constant.

The orifice flow at equilibrium is adjusted by the butterfly element, D, controlled by an external hand wheel. This allows flow adjustment over typically at 10:1 range. Once set to a flow rate, the Flostat maintains that flow independent of line pressure fluctuations, subject to certain minimum overall head loss requirements.

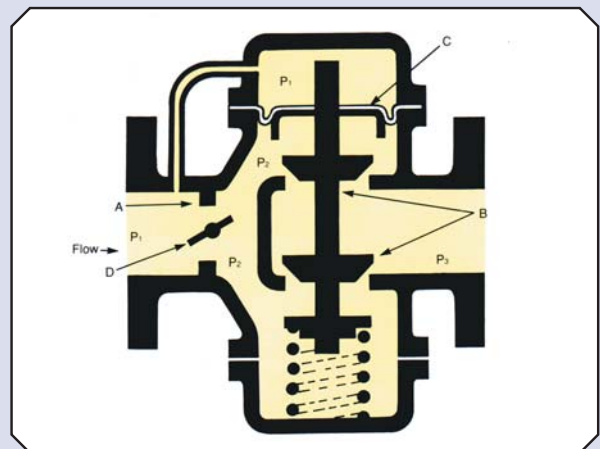



## MODELS AVAILABLE

For Liquids, the Flostet FV "Type A" units can be used for all applications, whether upstream or downstream pressures are subject to fluctuations.

For Gases or Steam, two Flostet versions are available, Type A or Type B. Accurate flow control requires that the pressure at the orifice is relatively constant, since gases are compressible.

Model FV Type A has the orifice on the upstream port, and is used when the gas or steam supply pressure is regulated or reasonably constant.

Model FV Type B has the orifice on the downstream port, and is used when the gas or steam has reasonably constant downstream pressure, or is discharging to atmosphere.

FLOSTAT FV UNITS ARE AVAILABLE IN TWO BODY STYLES, DEPENDING ON LINE SIZE/FLOW CAPACITY. THE SMALLER UNITS ARE 1/2" AND 3/4" LINES WITH BSP SCREWED CONNECTIONS.

## SPECIFICATION – STANDARD MODELS

Materials	1/2" – 3/4"	Brass (FVAB or FVBB) or 316 stainless steel (FVAS or FVBS)
	1" – 4"	Cast iron (FVC) or 316 stainless steel (FVS)
Valve Trim		Stainless steel
Diaphragm		Nitrile or PTFE
Connection	1/2" – 3/4"	BSP female threads
	1" – 4"	Flanged to BS, DIN or ANSI
Accuracy	Liquids	± 2%
	Gases	± 3%
Repeatability		± 1%
Rangeability		10:1 turndown of flow
Max pressure		16 bar (or flange rating if lower)
Max controllable pressure (P1-P3)		8 bar
Max temperature		80°C with nitrile diaphragm
		100°C with PTFE diaphragm
Flow scale plate		Standard on 1" – 4" units
		Option on 1/2" – 3/4" units

## OPTIONS AVAILABLE

Flange fittings available on 1/2" and 3/4" models. Higher pressure ratings (up to 140 bar) and pressure drops. Larger size units to 6". Models degreased for oxygen service. Steam flow models for up to 190°C, using stellite valve seats and stainless steel bellows. Factory preset units. Flow calibration scales for actual process fluids and conditions.

## TYPICAL APPLICATIONS

- Accurate blending or dispensing
- Heating or cooling constant flow
- Fuel flow to multiple burners
- Constant irrigation flow
- Flow control to aircraft refuelling metering skids
- Reverse osmosis flow balancing
- Overspeed protection for pumps and meters
- Avoiding pressure surge problems
- Providing stable process conditions
- Filter flow control
- Protection against system failure on single line breakage

## FLOW RANGES AND MODELS

Model (Type and Material)	Size		Range Code	Water Flow (20°C) m <sup>3</sup> /hr	Air Flow (ATP) m <sup>3</sup> /hr	Minimum Pressure Drop (P <sup>1</sup> -P <sup>3</sup> ) Bar
	Ins	mm				
Type A FVAB Brass FVAS Stainless Steel	0.5	15	1	0.02-0.27	0.08 – 8	0.5
			2	0.04-0.40	1.2 – 12	0.8
			3	0.08-0.80	2.4 – 24	1.0
Type B FVBB Brass FVBS Stainless Steel	0.75	20	1	0.05-0.54	1.6 – 16	0.5
			2	0.09-0.90	2.6 – 26	0.8
			3	0.16-1.60	4.6 - 46	1.0
Type A FVCA Cast Iron FVSA Stainless Steel	1	25	1	0.1-1	2.5-25	0.5
			2	0.2-2	6-60	0.8
			3	0.3-3	10-100	1.0
Type B FVCB Cast Iron FVSB Stainless Steel	1.5	40	1	0.2-2	6-60	0.5
			2	0.4-4	12-120	0.8
			3	0.8-8	25-250	1.0
	2	50	1	0.4-4	12-120	0.5
			2	0.8-8	25-250	0.8
			3	1.6-16	50-500	1.0
	3	80	1	0.8-8	25-250	0.5
			2	1.6-16	50-500	0.8
			3	3.2-32	100-1000	1.0
4	100	1	2.0-20	60-600	0.5	
		2	5.0-50	150-1500	0.8	
		3	7.5-75	220-2200	1.0	

## ALTERNATIVE FLUIDS

Consult our Sales staff for information on the flow ranges applicable to other liquids, or gases at different process pressures, for each model. Flow scales can be calibrated for the process fluids in use. Units for larger and smaller flow rates are available.

## SITE ADJUSTMENT

Operator adjustment of the flowrate through the Flostaf FV is via the external hand wheel, which controls the orifice size. On larger units, 1" - 4" line sizes, the handwheel is fitted with a pointer to indicate flow setting on a precalibrated scale plate. The handle can be locked in position. On 1/2" and 1/4" units the standard unit has no scale plate: flow is adjusted according to other process requirements or flowmeters. A scale plate can be fitted as an option.

Flow adjustment can be made over typically a 10:1 flow range. The tabulation shows the pressure drop (P1-P3) required for correct operation at maximum flow rate. This threshold value requirement decreases as the flow setting is reduced – the graph shows the relationship for a Range Code 3 model: normal operation is in the shaded area.

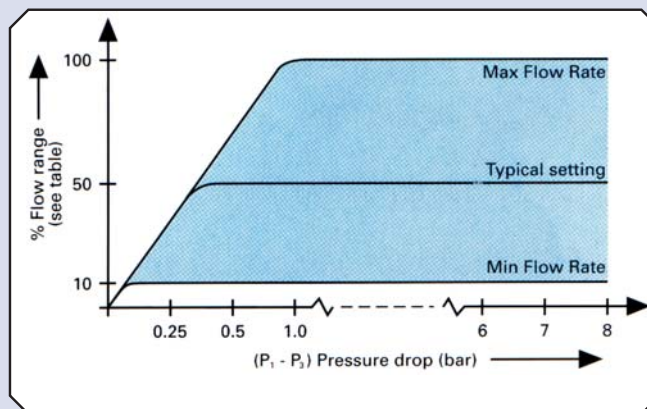

Dimensions		C	D	E	F	G	H	J	K	Weight
Size	mm									kg
1/2"	15	57	44	79	76	83	95	83	118	4.5
3/4"	20	64	51	95	100	102	108	95	150	8
Dimensions		L	M	N	P	Q	R	Weight		
Size	Mm							kg		
1"	25	127	102	117	168	117	98	13.5		
1 1/2"	40	152	114	138	189	121	102	23		
2"	50	181	130	170	265	136	121	32		
3"	80	216	140	176	271	140	130	50		
4"	100	241	140	197	292	146	136	68		

Arrows show flow direction for Flostat Types A and B.  
Dimension P refers to the Flostat with stainless steel bellows

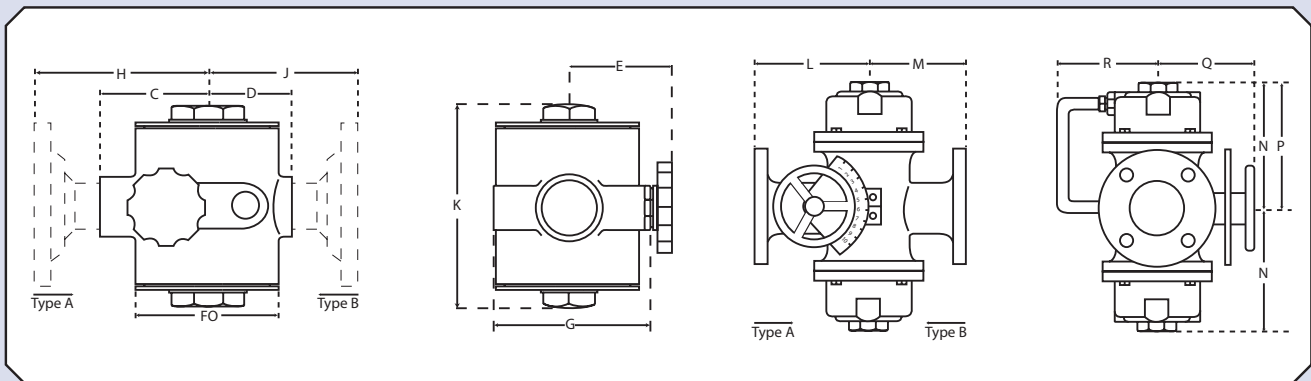

## INSTALLATION REQUIREMENTS

1. Flostats can be installed in any orientation.
2. A vent is fitted on the pressure housing on the top of the diaphragm to allow simple removal of trapped air on liquid Flostats on start up (when installed in horizontal pipework).
3. If possible, the Flostat should be installed with five diameters of straight pipework upstream, and three diameters downstream. (These dimensions are reversed for Type B models). This gives the flow measuring orifice the required working conditions.

## APPLICATION EXPERTISE

Flostat equipment has been manufactured by Platon for over 30 years for many different applications. Apart from providing sizing information for different process conditions, alternative designs are available to suit specific requirements. Please provide full application information for any enquiry, particularly specifying:

Pipeline size  
Fluid type, SG and viscosity if unusual  
Required body and diaphragm materials

Flow range required  
Fluid temperature pressure  
Flange type required

For special options, please specify if scale plate or factory preset flowrate required. For gas flows, advise whether Type A or Type B suits the pressure conditions best.

For lower flow rates (down to 2cm<sup>3</sup>/min), please consult leaflet DS1511 describing the Flostat Type MN.

Every effort has been made during the preparation of this document to ensure the accuracy of statements and specifications. However, we do not accept liability for damage, injury, loss or expense caused by errors or omissions made. We reserve the right to withdraw or amend products or documentation without notice.

Head Office: 2 Downgate Drive, Sheffield, S4 8BT, England  
Tel: +44(0)114 244 2521 Fax: +44(0)114 243 4838



**RM&C** Roxspur  
Measurement  
& Control Ltd

1-4 Campbell Court, Bramley, Tadley, Hampshire, RG26 5EG, England

Tel: +44(0)1256 884901 Fax: +44(0)1256 882986

email: [sales@roxspur.com](mailto:sales@roxspur.com) [www.roxspur.com](http://www.roxspur.com)



CERTIFICATE No. FM22358