

Platon Glass Tube VA Flowmeter

PLATON SAFETY HOUSED GAPMETER TYPE GU

Gapmeters type GU are glass tube Variable Area Flowmeters for direct display of liquid or gas flowrate. The GU housing provides a robust rigid frame, suitable for mounting directly into plant pipework, protecting the glass tube from pipework stress and random plant damage. The safety Perspex window gives good flow visibility, while protecting the operator. A safety blowout disc on the rear of the housing provides a relief vent for process fluids, in case of glass tube damage.

Glass tube VA flowmeters are simple and reliable in operation, and instantaneous in response – they offer flow visualisation to the operator, and the float rotation gives confirmation of correct meter performance. Standard tubes and floats offer low line pressure loss and a high resolution 100mm linear scale, fused into the glass tube. Fluid flow vertically upward through the tapered glass tube causes the float to rise to an equilibrium position. Flow rate is measured on the scale of the flow tube, along the top edge of the float.

The borosilicate glass tubes are individually scaled according to customer requirements, and individually flow calibrated.

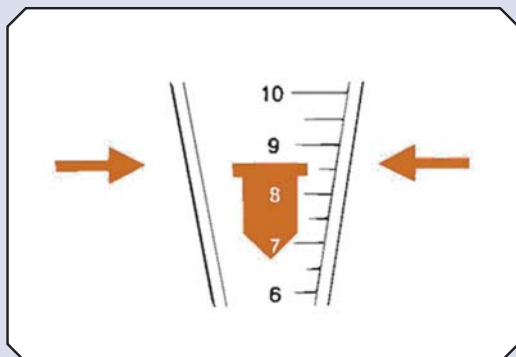

FEATURES

- Robust construction
- Instant flow rate visual indication
- Suitable for installation in unsupported pipework
- Flow tube scaled for any gas and most liquids
- Safety housed for operator protection
- Site interchangeable 140mm flowtubes



OPTIONS

- GIR Alarms
- Toughened Glass Window (Higher Temps)

SPECIFICATION - GTF FLOW TUBE

Tube	Borosilicate glass
Calibration	Custom scaled for gas or liquid and site conditions. Standard air and water flow tube ranges as overleaf
Scale Length	100mm
Scale markings	Fused ceramic ink
Accuracy	± 1.25% FSD standard (± 2.5% for 1CHD/1BHD models, ±3% for predicted scales)

ORDER CODE

GTF1AHS-B

Tube Size
(1, 2 or 3)

Tube Taper
(A, B or C)

Scale reference

Float material

HS = Hollow stainless
HD = Hollow dural
SS = Solid stainless

SPECIFICATION - GU HOUSING

Connections	3/8" BSP female (Optionally 1/2" ANSI/15mm EN flanged)
Housing	Polyester coated aluminium with polypropylene rear facing pressure relief vent
Window	Solid perspex
Max Pressure	25 bar (non-shock)
Max Temperature	100°C (viton seals) 80°C (nitrile seals)

ORDER CODE

GUS212

End connection blocks

S = Stainless steel
B = Plated brass
FS = Flanged S/S

Seal material

1 = Nitrile O-rings
2 = Vitron O-rings

Alarms

1 = Not fitted
2 = Low alarm

Tube fittings
(Size 1, 2 or 3)

ACCESSORIES

For fine flow control on a GU flowmeter installation, the FCV multi-turn needle valve is available in plated brass or stainless steel. FCV model flow ranges correspond to the three GTF tube sizes. Adaptors (type CVA) in brass or stainless steel allow the FCV to be connected directly to the GU flowmeter. Infra-red sensors can be fitted to the GU frame to monitor the float position and provide latching high or low flow alarms.

For higher pressure operation or where metal tubes are required, the API/APT Armoured Purgemeters should be considered.

FLOW RANGES

Model (for gases)	Air at ATP (1.013 bar + 20°C)
GTF 1 CHD-B	5-100 cm ³ /min
GTF 1 BHD-B	20-250 cm ³ /min
GTF 1 AHD-B	60-600 cm ³ /min
GTF 1 AHS-B	0.1-1.2 L/min
GTF 2 CHD-B	0.2-2 L/min
GTF 2 BHD-B	0.6-5 L/min
GTF 2 BHS-B	1-10 L/min
GTF 2 AHD-B	1-12 L/min
GTF 2 AHS-B	2-25 L/min
GTF 3 AHD-B	6-50 L/min
GTF 3 AHS-B	10-100 L/min
GTF 3 ASS-B	30-150 L/min
Model (for liquids)	Water at 20°C
GTF 1 AHS-C	2-25 cm ³ /min
GTF 1 ASS-C	10-80 cm ³ /min
GTF 2 BHS-C	20-280 cm ³ /min
GTF 2 AHS-C	50-800 cm ³ /min
GTF 2 ASS-C	0.2-1.5 L/min
GTF 3 AHS-C	0.2-3.0 L/min
GTF 3 ASS-C	0.4-4.4 L/min

Note: The tabulation gives typical air and water flow ranges. Tubes are custom scaled for the required fluids and line pressure/temperature conditions. A wide range of standard tube scales are available.

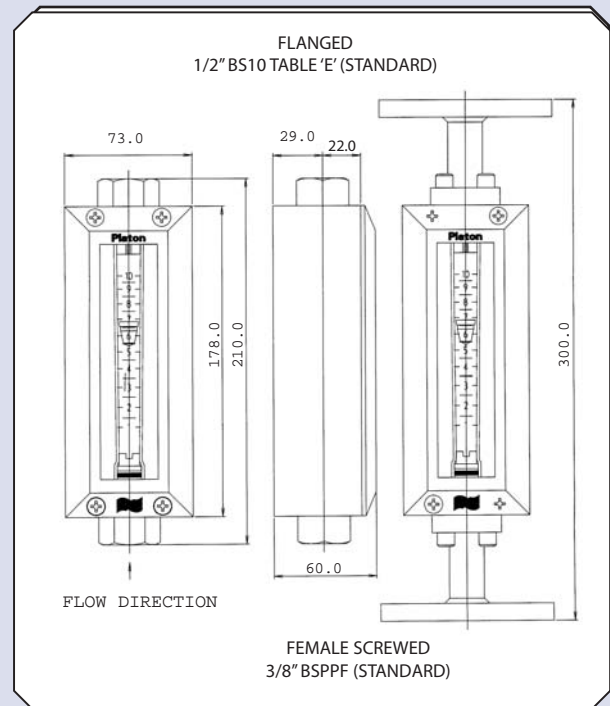

Every effort has been made during the preparation of this document to ensure the accuracy of statements and specifications. However, we do not accept liability for damage, injury, loss or expense caused by errors or omissions made. We reserve the right to withdraw or amend products or documentation without notice.

Head Office: 2 Downgate Drive, Sheffield, S4 8BT, England
Tel: +44(0)114 244 2521 Fax: +44(0)114 243 4838



RM&C Roxspur
Measurement
& Control Ltd

2 Downgate Drive, Sheffield, S4 8BT, England
Tel: +44(0)114 244 2521 Fax: +44(0)114 243 4838
email: sales@roxspur.com www.roxspur.com



CERTIFICATE No. FM22355

03HWAR0410