

Platon Flow Alarms For Glass VA

PLATON FLOSCAN INFRA-RED FLOW ALARM SYSTEMS

Platon Floscan sensors use an infra-red beam across the glass flowtube of a Variable Area (VA) flowmeter. Passage of the float between the sensor arms is detected, and logic within the electronics determines whether the float is above or below the sensor position. Electronics inside the sensor module gives an open collector transistor output, suitable for external logic circuits.

Suitable for all gas flows, and liquid flows where the float is visible, the sensor is clipped to the back of the flowmeter frame, typically on a Platon NG/NGX Series (normal 100mm scale) or LG/LGX series (miniature 30mm scale) VA meter.

Movement up and down the frame allows the sensor to provide a flow alarm at any point on the tube scale, as required. The sensor can also be supplied on Platon GU or SGUV style flowmeters.

The optional mains interface and relay module is used to provide the DC power needed to drive the sensor electronics, plus a SPCO 8 Amp mains relay output. This relay acts as a slave to the transistor output from the sensor module. Each Floscan relay module has two output relays, and can be used to monitor two separate alarm sensors.

FEATURES

- High or Low flow alarm
- Intelligent: Knows whether float above or below sensor
- Adjustable over full range of flowtube
- Suitable for normal (NG/NGX) or miniature (LG/LGX) flowmeters
- DC output direct to standard logic circuits
- Optional mains interface relay module



SPECIFICATION

Sensor Type	IR Beam break detection
Direction Logic	Position of float above/below sensor established on first detection of float after power up
Setting Position	Held by spring clip anywhere in flowtube operating range
Temperature Environment	-5 to +50°C
Dimensions	IP44 with cable exit downwards 22 x 66 x 30 (HxWxD) 5mm space needed behind frame. Spacers provided for use on NG/LG frames
Sensor Cable	2m, 3 core screened
Cable Functions	Red - positive Black - OV common White - Transistor output
Voltage Supply Output (Sensor Positioned with Cable Exit Down)	12V nominal, 8V - 26VDC range at 25mA Open circuit for low flow alarm, conducts for flow above switch point
Switch Points	For falling float, top edge of float at centre line of sensor. For rising float, switching occurs when base of float passes centre line
Approvals	ATEX approval EMC Directive 2004/108/EC

PRINCIPLE OF OPERATION

The Floscan sensor module positions an infra-red detector beam accurately side to side across the flowtube, at a pre-set level. The beam is transmitted through the flowmeter cover and glass tube walls, but is broken by the presence of the float. Two IR sensitive detectors, one above the other, monitor the passage of the float shadow: direction of float travel is determined by the order in which the detectors emerge from the shadow. This allows the sensor to remember whether the float is above or below the sensor position.

Because the NGX/NG/LGX/LG series frames are compact units, the Floscan module is designed to be mounted externally. Alignment is maintained by connecting the two transmitter/receiver lobes together around the back of the flowmeter frame, where the whole unit clips into the extrusion groves. For panel mounted flowmeters, this means the frame must be spaced forwards from the panel by approx 5mm – spacers are provided.

COMPATIBILITY

1. Frames

All standard GIR sensors are supplied with a fitting kit suitable for use on Platon NG, LG, NGX, or LGX style frames. (See Data sheet DS1112 or DS1115) The sensor can be supplied fitted within Platon GU or SGUV style housings.

2. Flow Fluid

GIR sensors are supplied set up for the flowtube size specified and either liquid or gas as the flowing medium. The sensors are not normally interchangeable between different sized flowtubes.

3. Flow Scales

For size 1 and 2 flowtubes, the flow scale artwork serial number (eg CA 141002) must be issue C or later (first digit). Otherwise the scale marks may interfere with the infra-red beam. For size 3 flowtubes, GIR sensors will work correctly on all previously supplied scale artworks.

Consult the sales office and specify flowtube and alarm sensor module together.

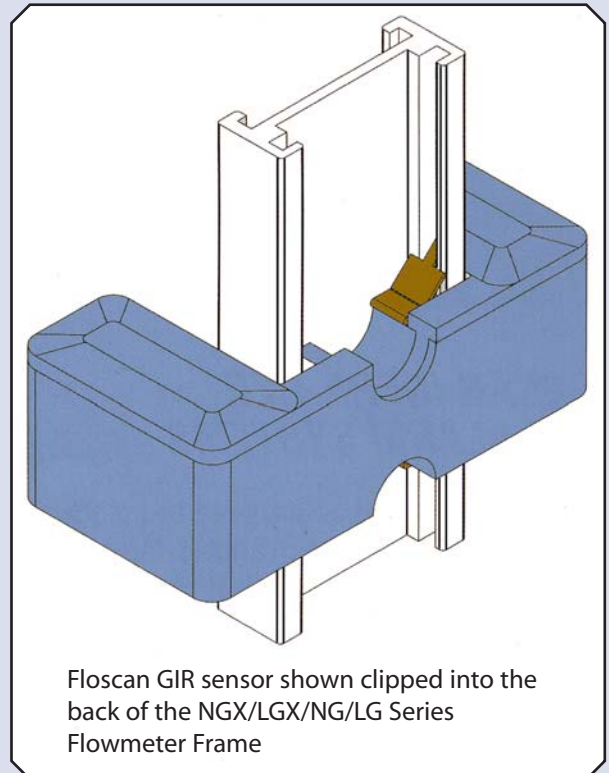

MODEL CODES

Typical

Floscan Sensor

Tube/Frame Size

1 = Size 1 flowtube

2 = Size 2 flowtube

3 = Size 3 flowtube

Fluid Type

L = Liquid

G = Gas

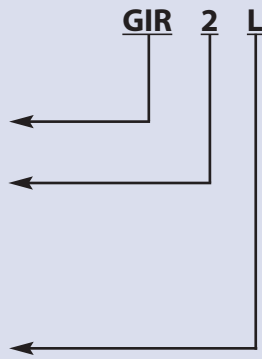

All GIR Floscan sensors are supplied with a fitting kit of retaining spring and two spacers for panel mounting of NGX/LGX and NG/LG frames.

OPTION - RELAY MODULE

The Floscan alarm optional mains power and slave relay output module is a DIN rail/surface mounted unit that provides DC power for one or two Floscan sensors.

Each sensor output drives a relay in the module, allowing external signalling via volt free contacts.

The two Floscan sensors can be high or low flow alarms (dictated by the sensor orientation), on the same flowmeter tube, or on separate flowmeters. "Energised relay normal" conditions are displayed by LED indicators.



OPTION - RELAY MODULE

- SPCO Relay Output
- Mains AC or DC Power
- LED Indicators
- Drives Two Sensors

OUTPUT LOGIC

For normal installation of sensor, with cable exit downwards, the output transistor conducts for flow rate above the set points.

START-UP LOGIC

On power-up, the sensor has no information as to whether the float is above or below the sensor. The output state is therefore indeterminate, and can represent high or low flow. Once the float has passed the sensor for the first time, the memory logic is triggered and the output validated.

EXTERNAL CONNECTIONS

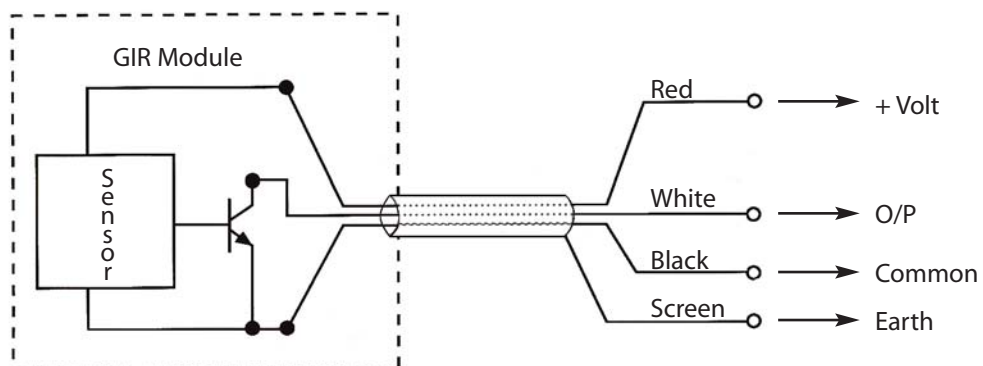

RELAY MODULE OPTION

Mains power interface
Suitable for one or two Floscan sensors

HAZARDOUS AREA INSTALLATION

The GIR sensor is approved as intrinsically safe to EEx ia IIC T4.

When used in hazardous areas the GIR sensor should be used with a 12Vdc supply, protected by 15 volt 100 ohm shunt diode safety barriers as - per RMRC drawing 2-W142.

Because the GIR module requires 8V & 25mA for correct operation, the barrier chosen must have an end to end resistance of below 16ohms. (A suitable barrier is the MTL767, with 155 ohm resistance).

The Platon relay module 58384 can be used to provide a control room interface, on the safe side of zener shunt diode safety barrier.

SPECIFICATION

Mains Power Input	20-256 Vac, 50/60Hz
Sensor Power Output	24-370 Vdc
Sensor Power Output	+12VDC, 12mA (suitable for GIR Alarm modules)
	+24VDC, 25mA (suitable for GMTXD transmitter)
Floscan Inputs	Two channel input, independent
Relay Output	8 Amp, 250VAC maximum SPCO action De-energised for sensor output circuit, typically a low flow condition
LED's	Green LED's for no alarm, (relays energised) Yellow LED for power on Red LED's to indicate that float position is unknown (occurs on switch-on before float passes sensor)
Temperature	-5 to +50°C
Dimensions	70 x 75 x 112 High
Terminal Covers	When fitted over terminals protection rating IP20
Order Code	58384 Floscan Alarm module.



CONNECTIONS

L	Live Power
N	Neutral Power
CH1	Relay output from Sensor 1
CH2	Relay output from Sensor 2
E	Earth bond
SCR	Sensor Cable Screen
S1	Sensor 1 input
S2	Sensor 2 input
OV	DC Common (OV)
+12V	Sensor supply (12V)
+24V	Sensor supply (24V)

Every effort has been made during the preparation of this document to ensure the accuracy of statements and specifications. However, we do not accept liability for damage, injury, loss or expense caused by errors or omissions made. We reserve the right to withdraw or amend products or documentation without notice.

Head Office: 2 Downgate Drive, Sheffield, S4 8BT, England
Tel: +44(0)114 244 2521 Fax: +44(0)114 243 4838



RM&C Roxspur
Measurement
& Control Ltd

2 Downgate Drive, Sheffield, S4 8BT, England
Tel: +44(0)114 244 2521 Fax: +44(0)114 243 4838
email: sales@roxspur.com www.roxspur.com



CERTIFICATE No. FM22358

03HWA R0410