

## Gapmeter Type RGT & RGTV

### INSTALLATION

1. Remove all packaging and check that the Float moves freely.
2. The instrument should be examined for any transit damage prior to installation.
3. Re-check that the instrument is suitable for the chosen application, ie Corrosion Resistance.
4. Select a location for the instrument to avoid:
  - a) Vapour condensation in instrument.
  - b) Settling out of sediment in instrument.
5. Include a bleed facility, if the process fluid is likely to freeze in the instrument.
6. Include a valved loop, if frequent instrument cleaning may be required.
7. The pipeline should be cleared of any foreign matter likely to inhibit instrument performance. A 50 micron filter should be fitted upstream of the meter, if particles larger than this might be present in the flow.
8. The upstream and downstream pipe bores should be the same nominal size as the instrument. Minimum straight pipe lengths of five diameters upstream and two diameters downstream are recommended.
9. Ensure the instrument is installed vertically in the pipe work with the direction of flow upwards.
10. Solenoid valves should NOT be used where they act directly on the instrument.
11. Avoid use of connections or pipe work at the instrument inlet, which will cause flow turbulence, likely to disturb the Float stability.
12. When using hazardous gases, it is advisable to remove the safety Grommet (item 17) and replace with suitable pipe work to vent off to a non-hazardous area.
13. When mounting on the front of a panel, ensure the Safety Grommet area is not obscured.
14. Read the top edge of the Float.

### MAINTENANCE

1. Recommended spares are shown with a double ring on Fig 2.
2. Spare Tube assemblies comprise of Tube, Float, top Float stop and bottom Float stop where applicable and are available by referring to the catalogue.
3. Please quote RM&C reference and/or your Purchase Order number, when requesting spares.
4. Refer to Datasheets and order acknowledgement for Instrument specification.

### TUBE & 'O'-RING REPLACEMENT

1. Slide the plastic Cover upwards until it is free from the End blocks (Ref Fig 1).
2. By pulling towards you, remove the plastic Wedge, located at the top of the assembly.
3. Slide the Tube upwards, towards the gap created by the removal of the plastic Wedge, until the top Insert is fully engaged in its End block. Ensure that the bottom Insert and End block remain engaged together.
4. Noting the Tube & Float orientation, tilt the bottom of the Tube towards you, until it is clear of the Insert, then pull downwards.
5. If the O-rings DO NOT require replacing, then jump to 11.
6. Remove both Inserts from their End blocks by pulling, noting which Insert came from which End block. To aid with their removal, the plastic Wedge can now be used as a sliding Wedge.
7. Remove 2x old O-rings from each Insert.
8. Care should be taken that the new O-rings are not damaged when assembling them to the Inserts.
9. Moistening the O-rings with a suitable lubricant is advisable, such that when reassembling to the End blocks or Tube, the O-rings are not damaged.
10. As previously noted, push the Inserts back into the appropriate End block, fully.
11. To replace the Tube, reverse steps 1-4, using steps 12 and 13, for guidance.
12. To aid engagement and reduce possibility of O-ring damage, rotate the Tube back and forth, whilst pushing the Tube and Insert together.
13. Once the Tube is located on the top Insert, use the plastic Wedge on the top Insert as a sliding Wedge to force the bottom Insert & Tube together.

**Dimensions:** C12/4 - RGT & RGTV and Surface Panel Mounting

ITEM	DESCRIPTION	MATERIAL	QTY	
			RGT	RGTV
1	Tube	Glass or TPX	1	
2	Float	Durallium or SS	1	
3	Unvalved End Block	SS or Brass		1
4	Valved End Bloc	SS or Brass	2	1
5	Backplate	Alu Alloy	-	1
6	Cover	Makrolon	1	
7	Wedge	Kemetal	1	
8	Top Insert	SS or Brass	1	
9	Bottom Insert	SS or Brass	1	
10	O-ring	Viton or Nitrile	2	
11	O-ring	Viton or Nitrile	2	
12	Counter Sunk Screw	St Zinc Plated	4	
13	Captive Screw	St Zinc Plated	2	
14	Nut	St Zinc Plated	2	
15	Washer	St Zinc Plated	2	
16	Grommet	Silicon Rubber	1	
17	Bottom Float Stop*	Polypropylene	1	
18	Top Float Stop	Polypropylene	1	
19	Valve Spindle	SS	-	1
20	Washer	SS or Brass	-	1
21	Bush	PTFE	-	1
22	Gland Nut	SS or Brass	-	1
23	Knob	Nylon	-	1
24	Knob Cap	Nylon	-	1

All Brass is Nickel Plated

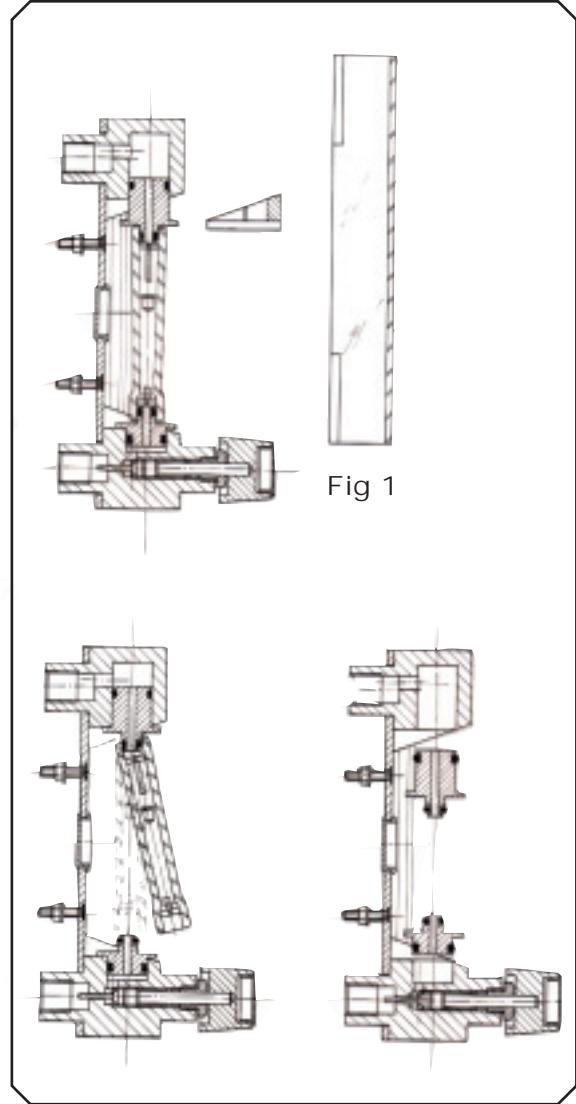
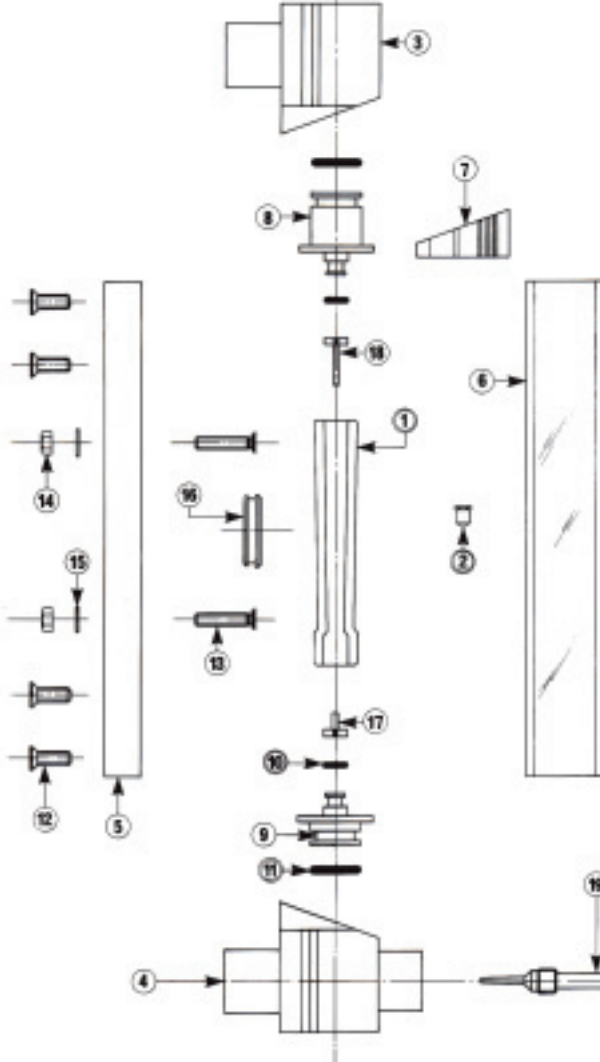

Fig 2

(Valved Model Shown for Reference Purposes Only)

Every effort has been made during the preparation of this document to ensure the accuracy of statements and specifications. However, we do not accept liability for damage, injury, loss or expense caused by errors or omissions made. We reserve the right to withdraw or amend products or documentation without notice.

Head Office: 2 Downgate Drive, Sheffield, S4 8BT, England  
Tel: +44(0)114 244 2521 Fax: +44(0)114 243 4838



0043

**RM&C** Roxspur  
Measurement  
& Control Ltd

10 Campbell Court, Bramley, Tadley, Hampshire, RG26 5EG, England  
Tel: +44(0)1256 884901 Fax: +44(0)1256 882986  
email: sales@roxspurmc.co.uk www.controlsdirect.com



CERTIFICATE NO. 22358