

Plastic Tube VA Flowmeter

GAPMETER TYPES PG & PGU

Gapmeters type PG and PGU are low cost direct reading variable area flowmeters for liquids or gases, in pipe sizes $\frac{1}{2}$ " or 1". The shatterproof TPX moulded tapered indicator tube has a 100mm linear flow scale with a 10:1 flow range. The stainless steel or Dural float rises with the flow to an equilibrium position - flow rate is read from the top of the float. Standard air and water scales are etched directly onto the plastic flow tube high float visibility, easily read at a distance.

Type PG is a lightweight, open construction ideal for surface mounting or portable use. For alternative process liquids or conditions, external laminated scales are provided positioned in front of the flow tube. Type PGU has a rigid diecast housing with a Perspex window, giving complete protection from random damage: this flowmeter is suitable for unsupported mounting in process pipework. TPX plastic tubes are available with air or water scales etched into the flow tube. Glass tubes are also available, which can be supplied with custom scales to suit process conditions, in the PGU housing.

The PG/PGU meters are installed vertically, with flow upward. End connections are either $\frac{1}{2}$ " or 1" BSPP standard: units with plated brass connections use Nitrile O-ring seals, with stainless steel connections the seals are Viton. Type PGU is also available with stainless steel flange connections, using Viton seals for the flow tube.

TPX plastic has excellent resistance to most chemicals and gases - it is also non-toxic and boilable.

FEATURES

- Large flow capacity for use on $\frac{1}{2}$ " and 1" lines
- High visibility
- Instantaneous in operation
- Suitable for use on a wide range of liquids and gases
- Glass tube or special scale options
- Low pressure drop



FLOW RANGES & MODEL CODES

Flow Range		Connection	PG-Open Frame		PGU-Safety Housed	
			Brass	S/Steel	Brass	S/Steel
Air Flow	10-100 L/m	1/2" BSP	PGB1	PGS1	PGUB1	PGUS1
At ATP	20-180 L/m	1/2" BSP	PGB2	PGS2	PGUB2	PGUS2
(20°C, 1.013B)	40-440 L/m	1" BSP	PGB3	PGS3	PGUB3	PGUS3
Water Flow (at	1-10 L/m	1/2" BSP	PGB4	PGS4	PGUB4	PGUS4
20°C)	2-22 L/m	1" BSP	PGB5	PGS5	PGUB5	PGUS5
	4-40 L/m	1" BSP	PGB6	PGS6	PGUB6	PGUS6

TECHNICAL DATA

Tube	TPX plastic
Scale	Black, hot block etched into tube surface for standard air/water scales
Float	Duralumin for gases Stainless steel for liquids
Accuracy	±5% FSD
Pressure Max	10 bar at 20°C
Temp Max	80°C
Housing	Model PGU Polyester coated die cast aluminium with perspex window Model PG White polyester coated mild steel open frame
Connections	1/2" or 1" BSPP female
Materials	Model PGB, PGUB Plated brass with Nitrile O-ring seals Model PGS, PGUS Stainless steel with Viton O-ring seals Model PGUFS Stainless steel flanged option
Installation	Install tube vertical with flow upwards. Read scale at top edge of float.

SPECIAL OPTIONS AVAILABLE

- Flanged or screwed connections to suit requirements.
- Special tube or float to individual requirements e.g. PTFE or metal cored PVC floats can be supplied for corrosive liquids or gases
- Special seal materials
- Special scale for alternative fluids or process conditions
- Glass flow tubes in PGU housings
- For opaque liquids or higher temperature GMT metal tube flowmeters are recommended. See DS1220.

PGU

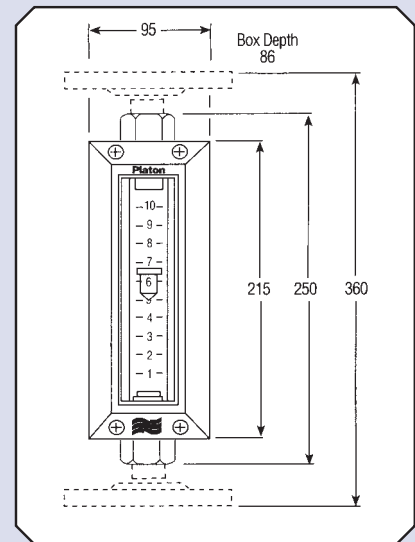

PG

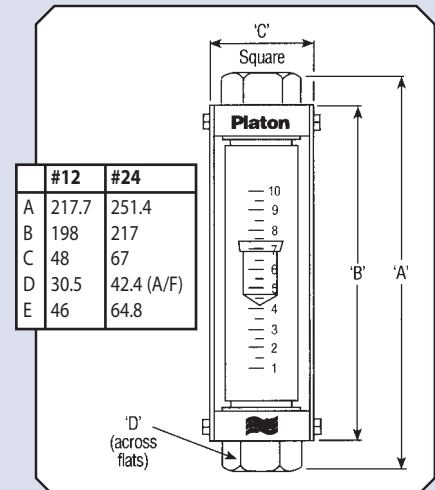

Every effort has been made during the preparation of this document to ensure the accuracy of statements and specifications. However, we do not accept liability for damage, injury, loss or expense caused by errors or omissions made. We reserve the right to withdraw or amend products or documentation without notice.

Head Office: 2 Downgate Drive, Sheffield, S4 8BT, England
Tel: +44(0)114 244 2521 Fax: +44(0)114 243 4838



RM&C Roxspur
Measurement
& Control Ltd

1-4 Campbell Court, Bramley, Tadley, Hampshire, RG26 5EG, England
Tel: +44(0)1256 884901 Fax: +44(0)1256 882986
email: sales@roxspur.com www.roxspur.com

