

LPCB Fire Sprinkler Flowmeter

BENEFITS

- Approved and Listed by LPCB for automated sprinkler systems
- 150 - 12,500 dm³/min range
- Easy and quick installation
- Flanged or Victaulic connections available
- Instantaneous reading
- Best in class flow ranges
- Isolation valves for tube replacement and cleaning
- Air bleed and drain valves
- Spare tube supplied



Approved and listed by the Loss Prevention Certification Board, and equivalent overseas authorities



SHUNT ORIFICE FLOWMETER FOR AUTOMATIC SPRINKLER INSTALLATIONS

The Shunt Gapmeter Model LPCB is approved for regular monitoring and testing of sprinkler systems by the LPCB, Loss Prevention Certification Board, under their 'Rules for Automatic Sprinkler Installations', in the UK, and by many equivalent organisations in other countries.

Model LPCB provides a compact, robust, direct reading flowmeter for 50mm-200mm pipelines and is suitable for use in horizontal or vertical pipes.

STANDARD SPECIFICATION

Orifice Plate:	Stainless Steel mounted in a 38mm thick, red polyester coated steel carrier ring
Measuring Tube:	Borosilicate Glass with 100mm fused-in ceramic scale
Float:	Stainless Steel
Accuracy:	±5% at various test flows specified by LPCB
'O' Seals:	Nitrile
Indicator Housing:	Die-cast Aluminium with white polyester coating, black bezel and perspex window
Inpulse Pipe:	Bright nickel plated copper with plated brass connections
Isolating Valves:	Full bore (8mm) brass ball valves bright nickel plated
Drain/Bleed Valves:	Brass, bright nickel plated with PTFE seat
Rodding Device:	Brass body, 316 Stainless Steel rod
Filter Unit:	316 Stainless Steel element with 1.5mm perforations, TPX tube, plated Brass connections and Nitrile 'O' seals
Temperature Limitation:	80°C
Pressure Limitation:	12 Bar g @ 20°C
Pressure Test:	30 bar hydraulic
Pressure Drop:	At max flow rate 65% of the orifice pressure loss of 354" WG is recovered
Installation:	As per manual OMM 1002
Approval:	Units approved by LPCB (UK)
LPCB Listing:	Approved Fire and Security products and Services Part 5, Automatic Sprinkler, Water Spray and Deluge Systems, Section 6: Direct Reading Flowmeters.

PRINCIPLE OF OPERATION

The Shunt Gammeter Model LPC is a combination of two simple measuring elements. In the main flow line an orifice plate is inserted, producing a pressure drop related to flow rate. Across the orifice plate, a shunt or bypass loop uses this pressure drop to create a small flow through a similar orifice restrictor and a Variable Area flowmeter. The flow in the bypass VA meter is proportional to the main line flow and special scaling on the glass tube allows the main line flow to be measured directly.

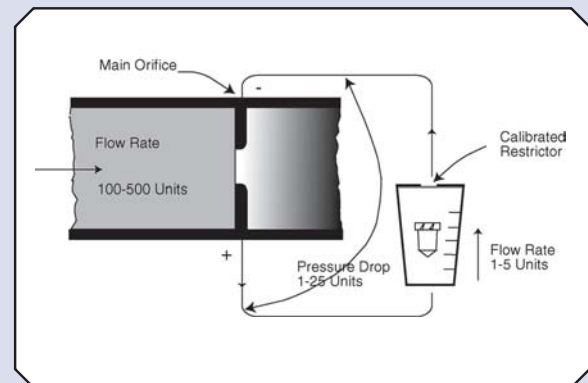

SPECIAL FEATURES

- Full bore isolating valves for meter isolation, filter cleaning or flow tube replacement.
- In-line filter avoids clogging of the bypass line or the flow restrictor with pipe debris. 'Rodding device' allowing the clearance of debris or algae from the orifice bypass restrictor.
- Bleed valves allowing drainage of the metering section and/or venting of trapped air.
- The flow tube is replaceable on site and a spare tube is supplied with each meter.

FLOW RANGES AND ORDER CODE

Flanged Carrier Ref's LPCB*	Platon~ Platon~	Groove Carrier Ref's LPCB*	Platon~ Platon~	Nominal Pipe Size (mm)	Flow Ranges dm ³ /min	Test Flows dm ³ /min	Accuracy@Test Flows dm ³ /min
088a/05	F1/5	088a/10	F1/10	50	150-750	500	±25
088a/06	F1/6	088a/11	F1/11	80	300-2300	800	±40
						1300	±65
088a/07	F1/7	088a/12	F1/12	100	500-3500	1500	±75
						2200	±110
088a/08	F1/8	088a/13	F1/13	150	900-8200	2500	±125
						3500	±175
						4500	±225
088a/09	F1/9	088a/14	F1/14	200	2500-12500	5000	±250
						7000	±350
						9000	±450

* The LPCB ref No. appears on the Carrier only

~ The Platon ref No. appears on both the Carrier & Tube.

Also, the Tube & Float assemblies of a particular NB are universal between the 2 carrier styles and therefore, carry both Platon Ref No's, ie F1/6 or F1/11.

INSTALLATION

RECOMMENDED PIPELINE CONFIGURATIONS

NOTE:

Pipeline configuration also approved without isolating valve.

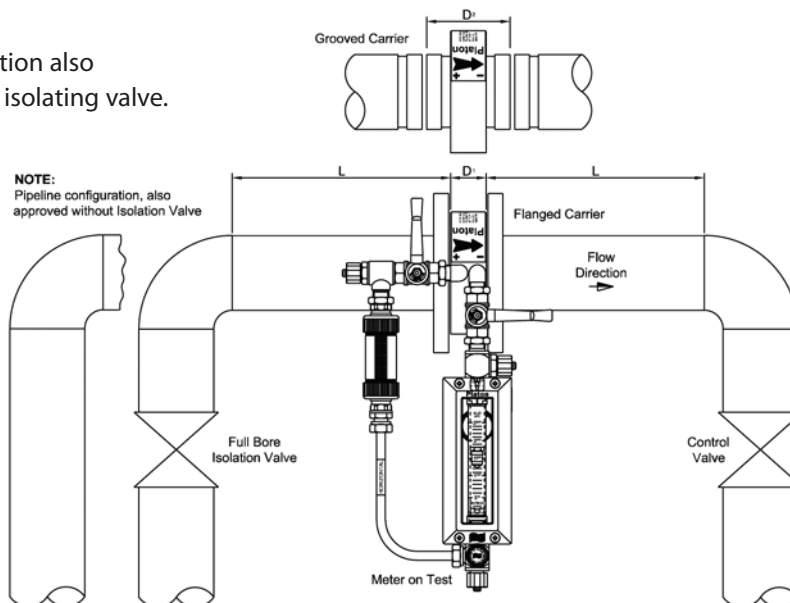

NOTE:
Pipeline configuration, also approved without Isolating Valve

The recommended minimum length of straight pipe required upstream and downstream of the orifice plate is defined by the table below:

Meter size		50mm	80mm	100mm	150mm	200mm
Recommended length of straight pipe	A	250mm	400mm	500mm	750mm	1000mm
	B	250mm	400mm	500mm	750mm	1000mm

EQUIPMENT SUPPLIED

- Shunt orifice flowmeter suitable for installation in horizontal pipelines
- Alternative pipe sections for installations in vertical up or down flow lines
- Spare glass indicator tube as required by LPCB
- Installation and Operation Manual OMM 1002

**SHUNT GAPMETER MODEL LPC
LPCB APPROVED DIRECT-READING FLOWMETER FOR WATER**

OVERALL DIMENSIONS AND INSTALLATION ARRANGEMENTS

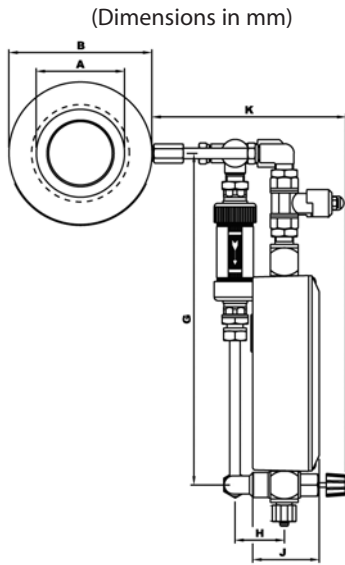

HORIZONTAL INSTALLATIONS

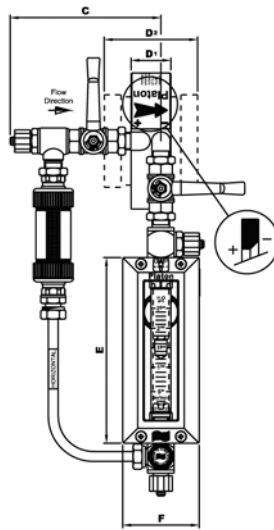

**HORIZONTAL
FLOW LEFT TO RIGHT**

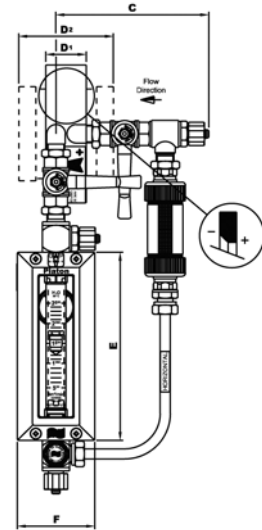

**HORIZONTAL
FLOW RIGHT TO LEFT**

Dimension 'A' = PIPE SIZE (50, 80, 100, 150 OR 200mm)

Dimension 'B' = FLANGE BOLT P.C.D. MINUS BOLT DIAMETER

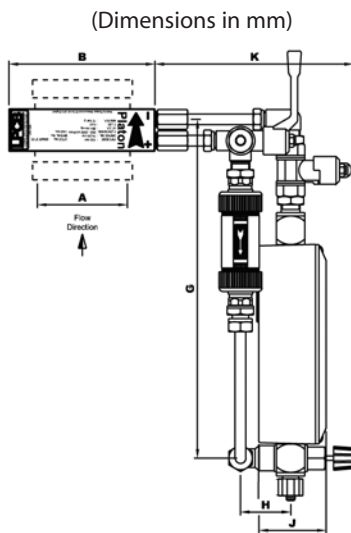

VERTICAL INSTALLATIONS

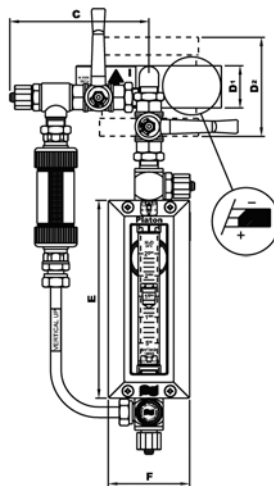

**VERTICAL
FLOW UPWARDS**

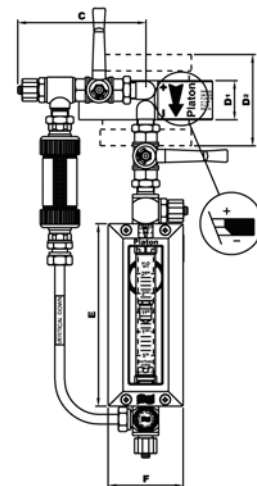

**VERTICAL
FLOW DOWNWARDS**

For more detailed dimensions, certified drawings, operation, installation and maintenance instructions and recommended spares etc, refer to Operation and Maintenance Manual OMM 1002.

Every effort has been made during the preparation of this document to ensure the accuracy of statements and specifications. However, we do not accept liability for damage, injury, loss or expense caused by errors or omissions made. We reserve the right to withdraw or amend products or documentation without notice.

Head Office: 2 Downgate Drive, Sheffield, S4 8BT, England
Tel: +44(0)114 244 2521 Fax: +44(0)114 243 4838



1-4 Campbell Court, Bramley, Tadley, Hampshire, RG26 5EG, England

Tel: +44(0)1256 884901 Fax: +44(0)1256 882986

email: sales@roxspur.com www.roxspur.com



CERTIFICATE No. FM22358