

Miniature Control Valve

AIR OPERATED CONTROL VALVE - THE 'M' VALVE

The M Valve is a miniature air operated proportional control valve for use on liquids, gases or steam. Available for 1/4" and 1/2" line sizes, a wide range of inner valve trims offer flow control with CV values from 3.0 down to 0.00008. Each valve has a control range of as much as 40:1 and with interchangeable trims the M Valve is ideal for pilot plant control, representing a scaled down version of larger process control valves.

With linear, equal percentage and quick opening control characteristics, the M Valve also has specific application in dosing, sampling and blending systems. Standard valve material is forged 316 Stainless Steel: alternatives of Hastelloy, Monel, PVC or Carbon Steel body materials are available with Stellite or other trim materials as required.

The standard Air actuator uses a 3-15 psi control input of either Air-to-Open or Air-to-Close. For higher line pressure applications a standard positioner is recommended, incorporated into the valve, either pneumatically or electrically operated. For high integrity applications, alternative designs of valve seal are available, such as bellow seals. Extension bonnets or cooling fins are used for cryogenic or high temperature duty.

FEATURES

- 1/4" or 1/2" proportional control
- Interchangeable trims
- CV values 0.00008 to 3.0
- Air operated
- Stainless Steel valve and trim standard
- Linear or Equal percentage control characteristics
- Accurate low flow control



**STANDARD
AIR-TO-CLOSE
VALVE**

VALVE SPECIFICATION

Body	Stainless Steel 316 S31 (Options : Carbon Steel, Monel, Hastelloy, PVC)
Trim	1/2" Valves: Sizes A-F: Stainless Steel 1/4" Valves: Sizes F-N: Stainless Steel 1/4" Valves: Sizes P0-P9: Drive Stem: 316 Stainless Valve plug: Stellite 6 Valve seat: 416 Stainless Steel (options: Hastelloy, Monel, Stellite)
Cv/Kv Values	See tabulation on back page
Control Range	Trims A-N: 40:1 Trims P0-P9: 12:1
Leak Rate	Less than 1% of max Cv/Kv when closed (the M valve is not an isolating valve)
Packing	Braided PTFE Standard (Options: Solid PTFE, Chevron or bellows seals)
Connections	1/4" or 1/2" NPT female (Options: flanges or weld fittings)
Pressure	150 Bar max (subject to valve packing)
Fluid Temperature	-75°C to 190°C (Options to 400°C with cooling fins)
Valve Stroke	1/4" valve 11mm 1/2" valve 14mm (Visual position indicator on valve stem)

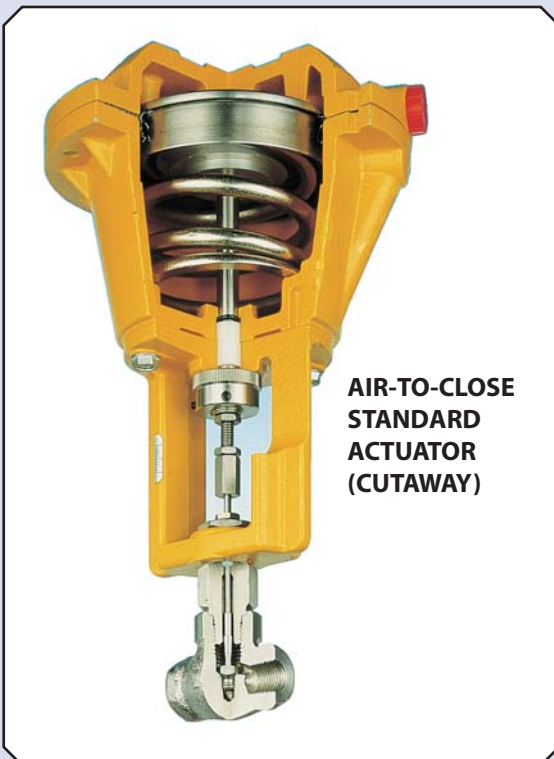

**AIR-TO-CLOSE
STANDARD
ACTUATOR
(CUTAWAY)**



**AIR-TO-OPEN WITH
PNEUMATIC
POSITIONER**

ACTUATOR SPECIFICATION

1. STANDARD PNEUMATIC ACTUATOR

Signal Input	Director acting 3-15psi clean dry instrument Air
Suitable Applications	Valve trims sized A-N, where pressure drop across valve does not exceed:
	Trims A-B: 63psi
	Trim C: 85psi
	Trims D-E: 140psi
	Trims F-J: 360psi
	Trims K-N: 1000psi

Positioning Accuracy Affected by pressure drop across valve: maximum offset 5% at DP quoted above

Connection Thread	1/4" NPT
Variants	Air-to-Open or Air-to-Close
Housing	Die-cast Aluminium
Rolling Diaphragm/Seals	Nitrile rubber
Temperature	-20°C to +50°C Ambient

2. PNEUMATIC POSITIONER

Type	Moore Products Positioner built onto standard Air motor
Suitable Applications	Valve Trims P0-P9 Valve Trims A-N, where increased positioning accuracy is required, or where pressure drop across valve exceeds the figures quoted for standard pneumatic actuator
Air Supply	Max: 100psi/Min: 5psi above required valve actuation pressure
Signal Input	3-15psi
Connection Thread	1/4" NPT
Variants	Air-to-Open or Air-to-Close
Temperature	-20°C to 50°C Ambient

HOW TO SPECIFY

To properly specify the process conditions and control requirements for an M Valve application, please supply the following information:

- Line size
- Connections required
- Valve materials preferred
- Fluid type (specify density and viscosity if unusual)
- Line pressure and temperature
- Maximum flowrate and flow control range required
- Upstream pressure
- Downstream pressure
- Valve characteristics
 - Air-to-Open or Air-to-Close
 - Linear or Equal % Trim
- Special conditions
 - eg particles or bubbles in fluid

CHOICE OF TRIM

FLOW RANGE

The M Valve body is fitted with a Trim plug and seat combination, matched together and sized to give the required flow rate control.

Trim sizing uses the Cv or Kv value, a parameter calculated for the specific site fluids and conditions according to standard formulae, as quoted overleaf.

The tabulation presented there shows, for each trim, the Cv/Kv value when the valve is fully open. For Trims A-N, control is available over a 40:1 range, representing flow rates between 2.5% and 100% of maximum. Smaller trims, sizes P0-P9, have a 12:1 control range available.

CONTROL CHARACTERISTIC

The normal control characteristics for all trim sizes gives a linear relationship between valve lift and flow rate. For Trim sizes A-J, an alternative characteristic is available: this is the Equal Percentage Trim, where equal increments of valve lift produce constant percentage increments of flow through the range. The graph shows this characteristic, where Equal Percentage trims have double the original flow for a 15% linear opening of the valve.

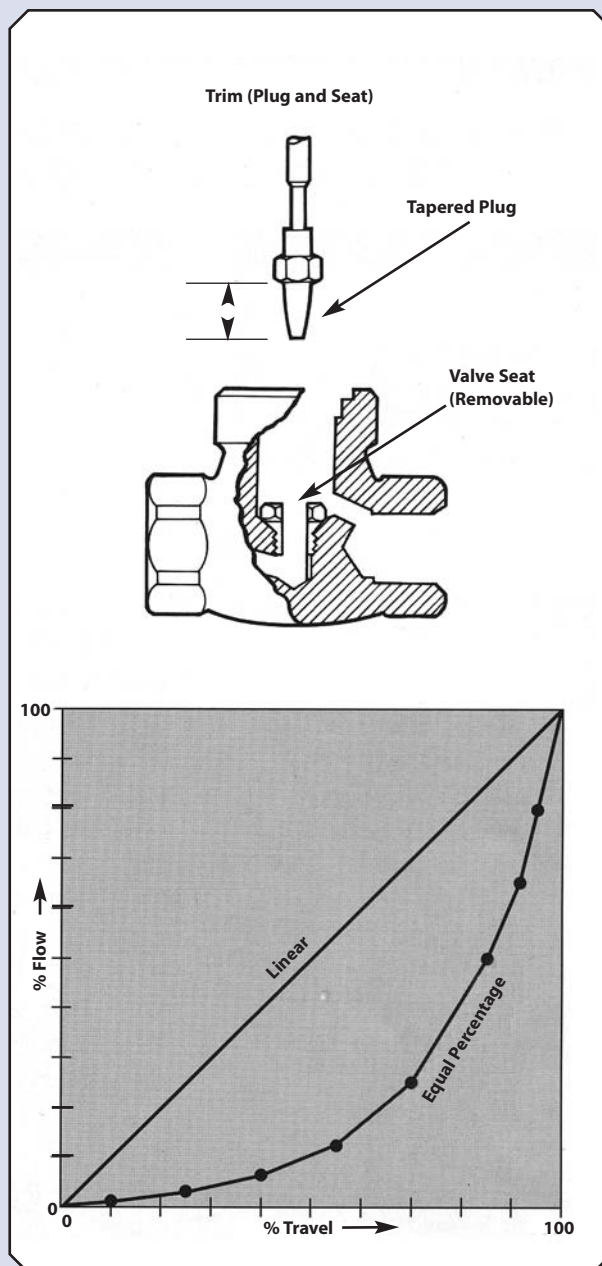

TRIM SIZING FORMULAE

The tabulation gives the Cv and Kv values for each Trim size, as calculated according to the formulae below:

US UNITS

SI UNITS

LIQUIDS

$$C_v = Q \sqrt{\frac{G}{\Delta P}}$$

Q = Flow US GPM
G = Specific Gravity (H₂O=1)
ΔP = Pressure Drop, psi

$$K_v = Q \sqrt{\frac{G}{\Delta P}}$$

Q = Flow m³/h
G = Relative Density (H₂O=1)
ΔP = Pressure Drop bar

GASES

$$C_v = \frac{Q}{60 \sqrt{\frac{293 P \Delta P}{GT}}}$$

Q = Flow, SCFH
G = Specific Gravity (Air=1)
T = Temperature, °K
P = Inlet Pressure psia
ΔP = Pressure Drop psi

$$K_v = \frac{Q}{29 \sqrt{\frac{293 P \Delta P}{GT}}}$$

Q = Flow Nm³/h
G = Relative Density (Air=1)
T = Temperature °K
P = Inlet Pressure, bar abs
ΔP = Pressure Drop, bar

STEAM

$$C_v = \frac{W}{63 \sqrt{\frac{V}{\Delta P}}}$$

W = Flow lbs/hour
V = Specific Volume, ft³/pound
ΔP = Pressure Drop, psi

$$K_v = \frac{W}{31.7 \sqrt{\frac{V}{\Delta P}}}$$

W = Flow, kg/h
V = Specific Volume, m³/kg
ΔP = Pressure Drop, bar

TRIM	Cv MAX	Kv MAX
A	3.0	2.6
B	2.0	1.7
C	1.25	1.1
D	0.8	0.7
E	0.5	0.43
F	0.32	0.27
G	0.2	0.17
H	0.13	0.11
I	0.08	0.07
J	0.05	0.04
K	0.03	0.026
L	0.02	0.017
M	0.01	0.0086
N	0.006	0.0052
P0	0.003	0.0026
P1	0.002	0.0017
P2	0.0013	0.0011
P3	0.001	0.00086
P4	0.0006	0.00052
P5	0.0004	0.00034
P6	0.00027	0.00023
P7	0.00018	0.00015
P8	0.00012	0.0001
P9	0.00008	0.00007

NOTE: Liquid formula applies only to clean, bubble free liquid with no cavitation or flashing and with Reynolds Number 100,000 minimum.

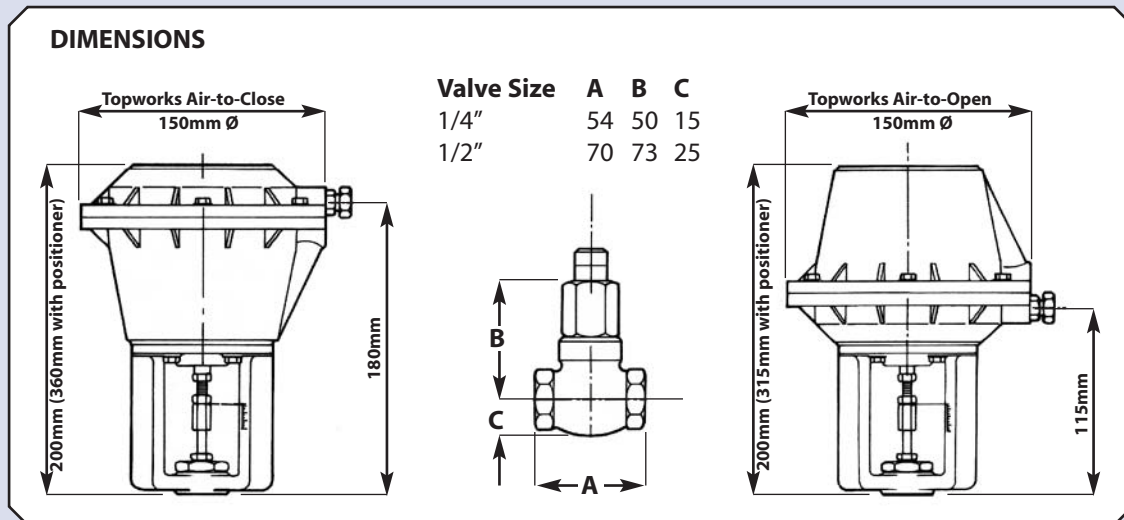

Every effort has been made during the preparation of this document to ensure the accuracy of statements and specifications. However, we do not accept liability for damage, injury, loss or expense caused by errors or omissions made. We reserve the right to withdraw or amend products or documentation without notice.

Head Office: 2 Downgate Drive, Sheffield, S4 8BT, England
Tel: +44(0)114 244 2521 Fax: +44(0)114 243 4838



RM&C Roxspur
Measurement
& Control Ltd

1-4 Campbell Court, Bramley, Tadley, Hampshire, RG26 5EG, England
Tel: +44(0)1256 884901 Fax: +44(0)1256 882986
email: sales@roxspur.com www.roxspur.com



CERTIFICATE No. FM22358